



## Datenblatt - *Data sheet*

### Maschinenschraubstock - Machine vice

**BMS 85**

**BMS 100**

**BMS 120**

**BMS 150**

**BMS 200**

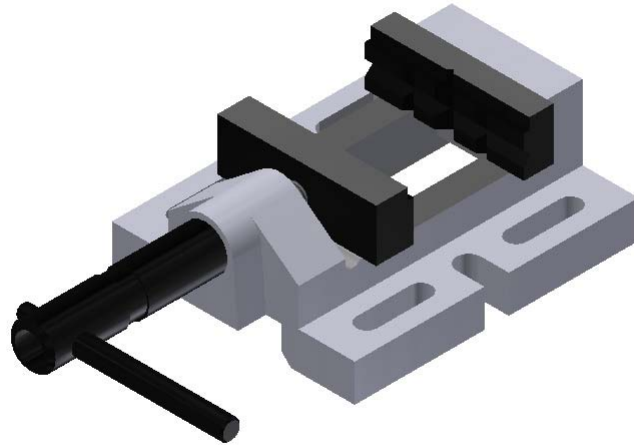





## 1.1 Ersatzteile - Spare parts

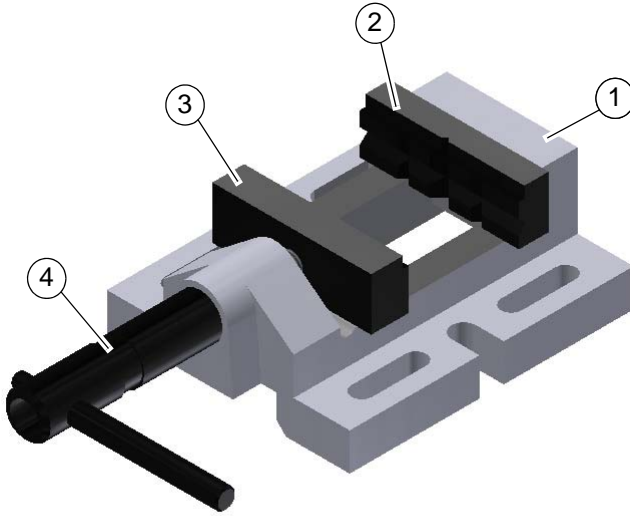

Pos.	Bezeichnung	Designation	Menge Qty.	Artikelnummer				
				Item no.				
				BMS 85	BMS 100	BMS 120	BMS 150	BMS 200
1	Gusskörper	Casting parts	1	0300000851	0300001001	0300001201	0300001501	0300020001
2	Feste Backe	Steady jaw	1	0300000852	0300001002	0300001202	0300001502	0300020001
3	Bewegliche Backe	Follow jaw	1	0300000853	0300001003	0300001203	0300001503	0300020001
4	Spindel komplett	Complete spindle	1	0300000854	0300001004	0300001204	0300001504	0300020001

# OPTIMUM

MASCHINEN - GERMANY

